

DYNARIGID

HIGH SPEED SECURITY DOORS

Dimensions and installation requirements

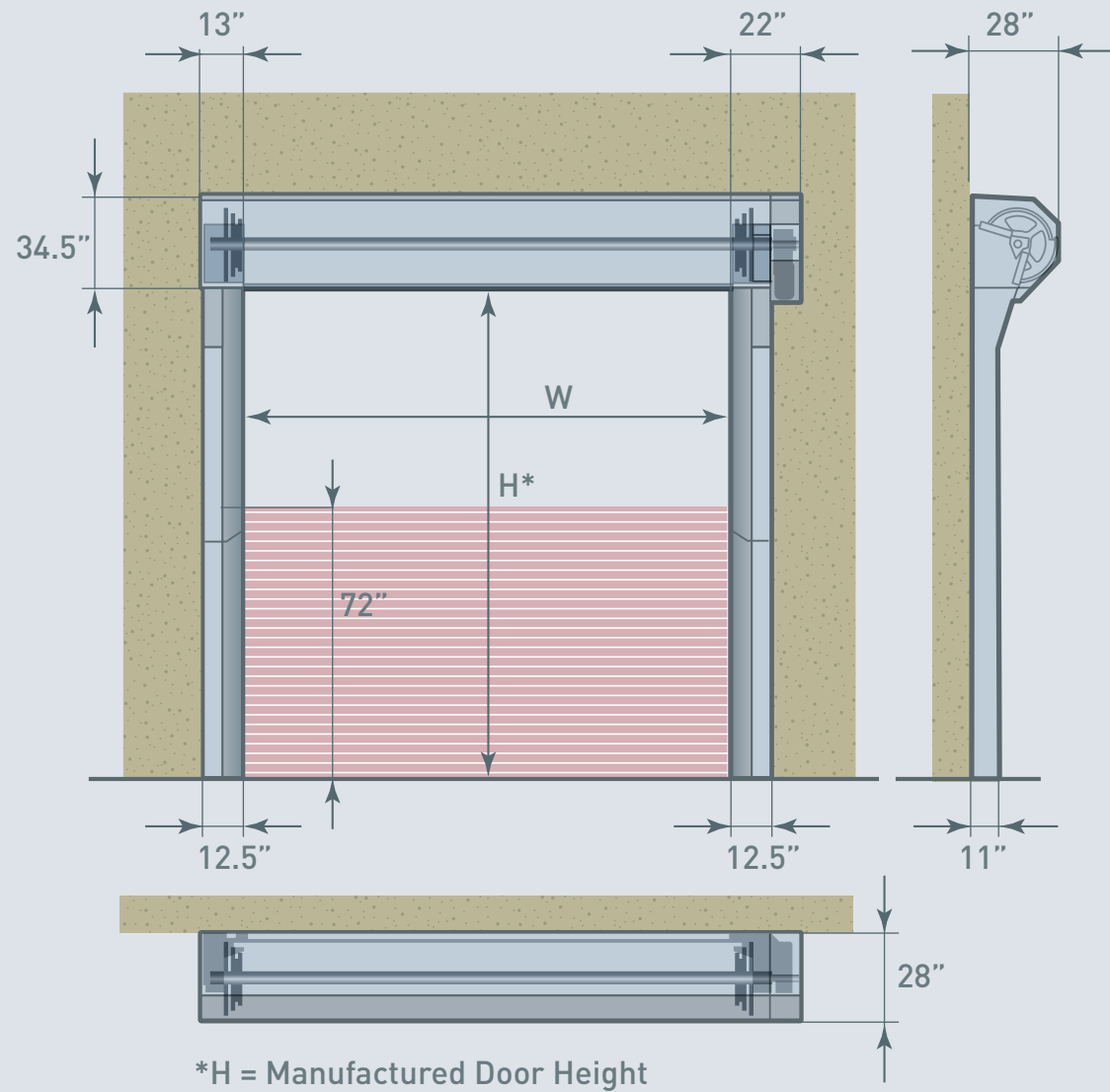

All indicated dimensions are net: the space necessary for mounting and maintenance has to be provided.
REMARK: Based on the risk analysis of the environment, extra push buttons, detectors and covers might be required.

© All rights reserved by Dynaco - 2014

The DYNACO Entrematic products are protected by worldwide registered patents. As part of its policy of continuous product development, DYNACO reserves the right to change the characteristics of its products or components without prior notice.

Disclaimers:
For a correct use of our products, please refer to our manual. Everything that is mentioned in this brochure is only valid under the terms of use in the user manual and on condition that the door was properly installed and maintained and has not undergone abuse nor neglect.

DYNARIGID

HIGH SPEED SECURITY DOORS



HIGH PERFORMANCE DOOR SOLUTIONS

P: 1-800-459-1930 P: 847-562-4910 F: 1-800-459-1960
Email: dynaco@dynacodoor.us www.dynacodoor.us



12718 E Indiana Ave
Spokane, WA 99216
(509) 921-2260 • (509) 921-5099 Fax
www.continentaldoorco.com





Security, Speed, and Beauty

Whether interior or exterior, if you need security, speed and aesthetic appeal, this is the door for you. The DYNARIGID is perfect for auto dealerships, parking garages, convention centers, hotels, and a multitude of other applications. It's the perfect combination of brains, brawn and beauty.

Security and Vision

Reinforced, high strength aluminum slats provide for the ultimate in security, and if accidentally impacted can be replaced in less than 15 minutes. Also, available are partial or full, equally strong clear window slats and/or perforated slats for multiple vision options, and circulation/ventilation, if necessary. More importantly, our doors have no external rubber gaskets between the slats, which can be sliced into for possible intrusion. And, with wind resistance of up to 90 miles per hour, your exterior is well protected.

Aesthetics

One look at this marvel of engineering immediately tells you that it is not only security strong, but it is architecturally and visually striking. When you combine all the features of this door, you increase your inside or outside curb appeal. Curb appeal sells.

Safety

Safety is no accident. DYNARIGID doors have a unique auto-reversing, in-line, light curtain built into the side frames, eliminating the need for externally mounted sensors which are subject to damage and malfunction. As an added safety feature, the DYNARIGID incorporated a wireless door bottom sensor that automatically stops and reverses the door to provide the ultimate in safety.

Speed

Speed translates into more productivity, increased traffic flow, and lower energy costs. Moving at up to 96" per second up and 24" per second down, we are the fastest door on the market.

Sealing

The unique DiscDrive technology makes possible our highly functional side frames that will not allow air, water, dust, pests or other contaminants into your space when the door is shut. And, combined with our superior open/close speed advantage, means minimal opportunity for infiltration.

DYNALOGIX II Controller

Our exclusive DYNALOGIX II Controller is user-friendly, has an absolute encoder for smooth starts and stops, and a complete self-diagnostic system for quick service.

DiscDrive Technology

DiscDrive technology is designed to keep the door running smoothly even with hundreds of cycles per day. And, with minimal moving parts, between 50% and 75% fewer than any other door of its kind, that translates into high-end reliability.

CHARACTERISTICS

Min. dimensions	W 4'-0" x H 8'-0"
Max. dimensions	W 17' x H 16'
Opening speed	Up to 96 in/s
Closing speed	24 in/s
Structure	Galvanized steel. Spring covers in galvanized steel standard
Door blade	Double wall aluminum slats. Option window slats.
Motor	4 poles, with parking brake - power: 1.1 kw
Control box	Includes DYNALOGIX II door controller, fused rotary disconnect, 24 vac control transformer, and variable frequency drive.
Safety device	Standard light curtain integrated in the side frame. Active height = 72".
Bottom edge detector	Wireless DYNACO detector (WDD).
Power supply	Single phase: 230 vac - 20 A
Frequency	Three phase: 208 - 230 vac - 20A, 460 vac - 10A, and 575 vac - 6A Frequency: 50 - 60 Hz

EN 13241-1 STANDARDS

Standard	Ref.	Test acc.	Result
Water permeability	EN 12425	EN 12489	Class 1
Wind load	EN12424	EN12444	Class 4*
Wind permeability	EN 12453	EN 12427	Class 2
Safe opening	EN12453	EN 12445	Pass
Mechanical resistance	EN 12604	EN 12605	Pass
Unintended movements	EN 12604	EN 12605	Pass

* The indicated class for wind resistance applies for doors up to W 138". Above 138": Class 3

Built-In, In-Line Light Curtain for Safety



Quick and Easy Repair and Maintenance



Total Security



High Speed Disc Drive Technology

